

Bylaw 15971

A Bylaw to amend Bylaw 7044, as amended,
being the Yellowhead Corridor Area Structure Plan

WHEREAS pursuant to the authority granted to it by the Planning Act, on April 13, 1983, the Municipal Council of the City of Edmonton passed Bylaw 7044, as amended, being the Yellowhead Corridor Area Structure Plan; and

WHEREAS Council found it desirable to from time to time amend Bylaw 7044, as amended, Yellowhead Corridor Area Structure Plan through the passage of Bylaws 7803, 7811, 7815, 9673, 9879, 9997, 10653, 11139, 11101, 11343, 12076, 12387, 13162, 13497, 13574, 13668, 14122, 14776, 15187, 15377, 15624 and 15843; and

WHEREAS an application was received by Sustainable Development to further amend the Yellowhead Corridor Area Structure Plan; and

WHEREAS City Council considers it desirable to amend Bylaw 7044, as amended, the Yellowhead Corridor Area Structure Plan

NOW THEREFORE after due compliance with the relevant provisions of the Municipal Government Act RSA 2000, ch. M-26, as amended, the Municipal Council of the City of Edmonton duly assembled enacts as follows:

1. Bylaw 7044, as amended, the Yellowhead Corridor Area Structure Plan is hereby further amended by:

- a) deleting the map entitled "Bylaw 14776 Amendment to the Yellowhead Corridor Area Structure Plan – Schedule C-4, Sub-Area 4" and substituting therefore the map entitled "Bylaw 15971 Amendment to the Yellowhead Corridor Area Structure Plan – Schedule C-4, Sub-Area 4" attached hereto as Schedule "A" and forming part of this Bylaw

READ a first time this	30th	day of	January	, A. D. 2012;
READ a second time this	30th	day of	January	, A. D. 2012;
READ a third time this	30th	day of	January	, A. D. 2012;
SIGNED and PASSED this	30th	day of	January	, A. D. 2012.

THE CITY OF EDMONTON

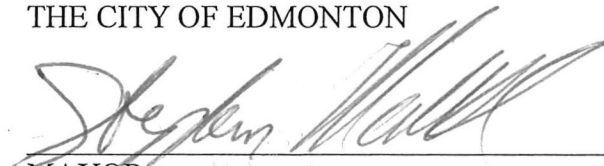

MAYOR



CITY CLERK

SEE DETAIL

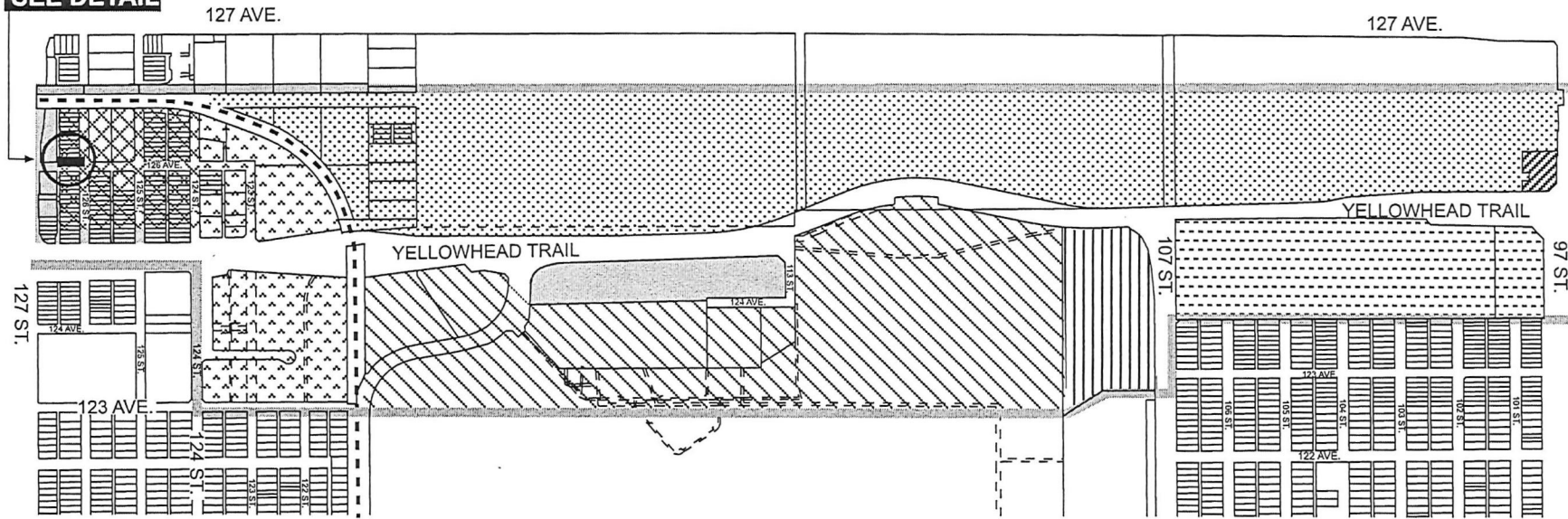

DETAIL

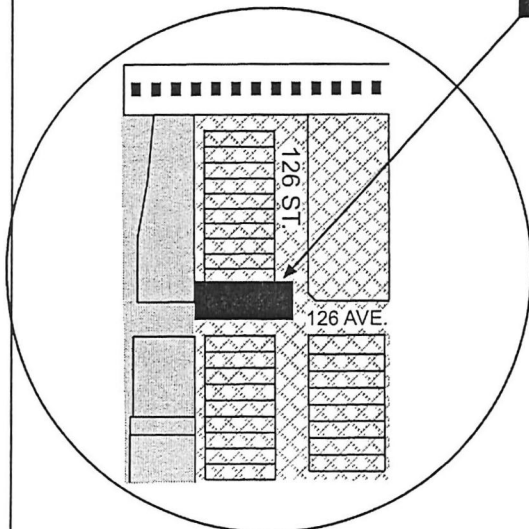



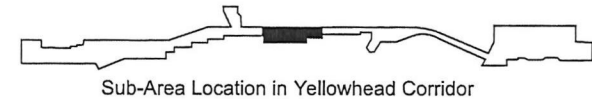







**Proposed Amendment from
"Medium Industrial" use
to "Light Industrial" use.**



Sub-Area Location in Yellowhead Corridor

**BYLAW 15971
AMENDMENT TO THE
YELLOWHEAD CORRIDOR AREA STRUCTURE PLAN
SCHEDULE C-4, SUB-AREA 4
(as amended)**



- | | | | |
|---|--------------------------------|---|---|
|  | Medium Industrial |  | Beechmount Cemetery |
|  | Light Industrial |  | CNR, Calder Yards and Intermodal Facilities |
|  | "Prestige" Business/Industrial |  | Municipal Airport |
|  | Public Utility |  | Commercial |
|  | Proposed N.W. LRT Line |  | Area Structure Plan Boundary |
|  | Special Study Area #2 | | |

SUSTAINABLE DEVELOPMENT